

LOL-ING-0232

Model No	LOL-ING-0232
Application	Inground
Name	Drive Way Light
Description	
<p>A luminaire designed to mount flush with the level of the path. A 'Flush Fit' lens stops water pooling and depositing dirt on the lens. There is no lip to trip over. The luminaire can be driven over or walked upon without damaging it.* Designed so the lamp can be angled up to 20 degrees directed at garden feature, without the need to remove the luminaire from the mounting canister. The vandal-resistant three allen head screw fixing system attaches the flange to the body of the luminaire.</p>	
Power Input	12V AC, 24V DC, Series
Lamp details	MR16
Power Usage	4W-7W
Beam Angles	varies with lamp
Colour Temperature	2700k, 3000k
Lumen	varies with lamp
CRI	90+
Dimming System	
IP	
Finish	Bronze, Stainless Steel
Mounting	Supplied with a mounting canister for casting in concrete to facilitate ease of installation
Dimensions	152Ø x 163H
Product Notes	
* Maximum drive over speed 10 km/h and weight 1500 kg	
Installed in canister with 3 stainless steel allen head screws.*internal tilt of lamp 0-20 degrees, 360 rotation	
IP68 Joining Kit	YES

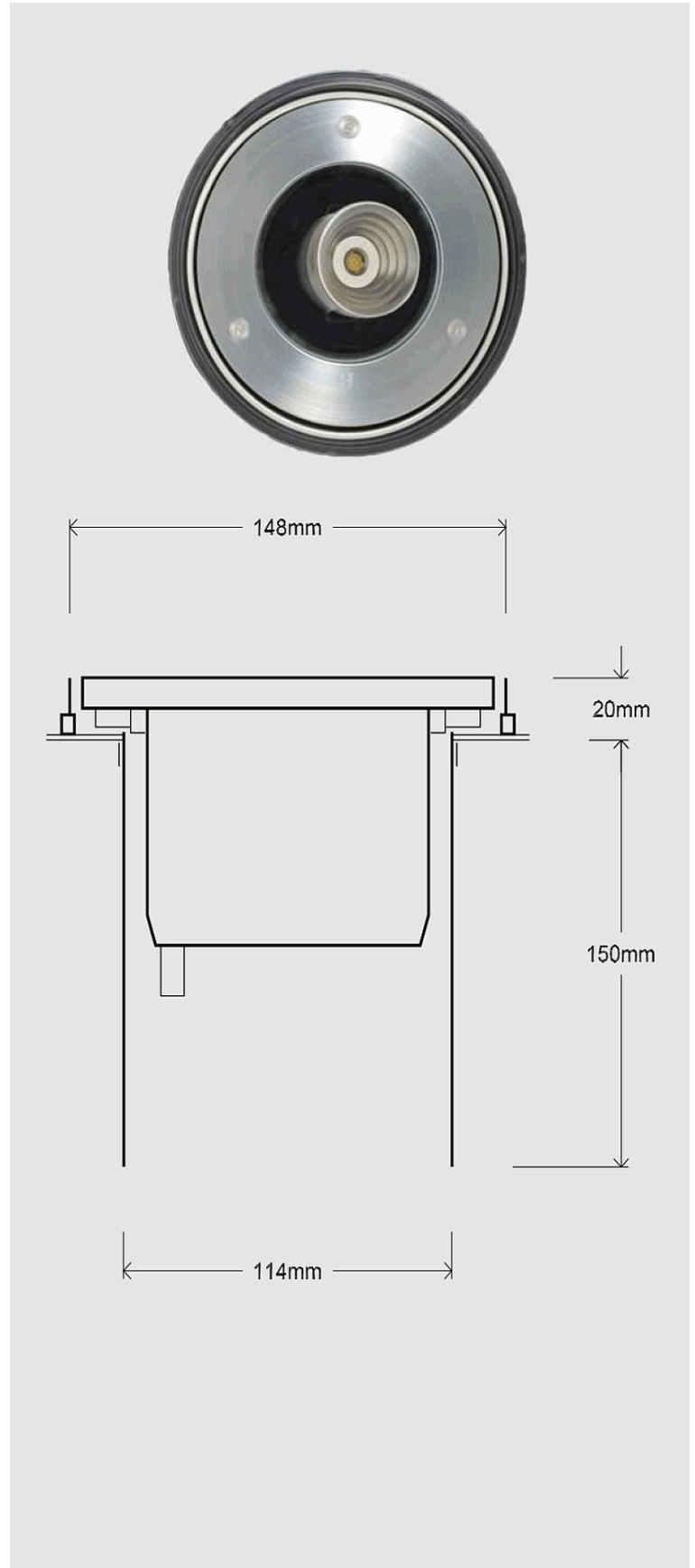

General Notes

Please contact Light on Landscape to confirm the availability and current specifications of this luminaire.

Installation

Light on Landscape strongly recommend that all luminaires be correctly installed and maintained. Failure to do so will result in the voiding of the manufacturer's warranty and the reduced efficiency, performance and life of the fixture. To eliminate voltage drop, we advise that the recommended UV stabilized cable and run lengths are used, along with soldered joins, heat shrink connectors and quality lamps.
